

- 1 A small block of wood is held at a horizontal distance of 1.2 m from a metal ball. The metal ball is fired horizontally towards the block at a speed of 8.0 m s^{-1} . At the same instant the ball is fired, the block is released and it falls vertically under gravity.

Fig. 8.1 shows the paths of the metal ball and the block. The ball collides with the block. Air resistance is negligible.

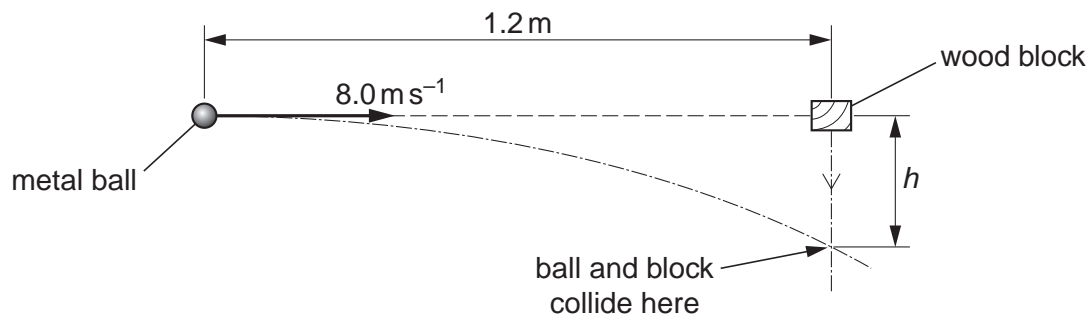

Fig. 8.1

- (a) Show that the time between firing the ball and it colliding with the block is 0.15 s.

[1]

- (b) Calculate the vertical distance h fallen by the wooden block when it collides with the metal ball.

$h = \dots\dots\dots \text{ m}$ [2]

(c) Briefly explain why the metal ball will always collide with the wood block, even if the speed of the ball or the horizontal distance is changed.

.....

.....

..... [1]

[Total: 4]

- 2 (a) Draw a line from each unit on the left-hand side to the correct equivalent unit on the right-hand side.

joule (J)

kg m s^{-2}

watt (W)

N m

newton (N)

J s^{-1}

[2]

- (b) This question is about estimating the pressure exerted by a person wearing shoes standing on a floor, see Fig. 1.1.

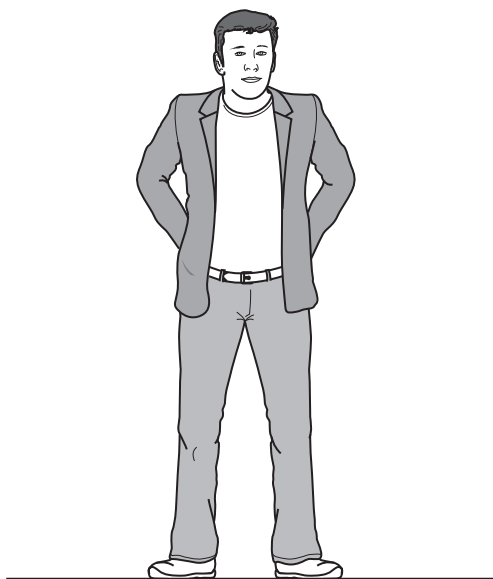

Fig. 1.1

- (i) Estimate the weight in newtons of a person.

weight = N [1]

- (ii) Estimate the total area of contact in square metres between the shoes of this person and the floor.

area = m² [1]

- (iii) Hence estimate the pressure in pascals exerted by this person standing on the floor.

pressure = Pa [1]

[Total: 5]

3 (a) Define a *vector quantity*.

.....
..... [1]

(b) Circle all the vector quantities in the list below.

acceleration speed eight [1]

(c) Fig. 1.1 shows graphs of velocity v against time t for two cars **A** and **B** travelling along a straight level road in the same direction.

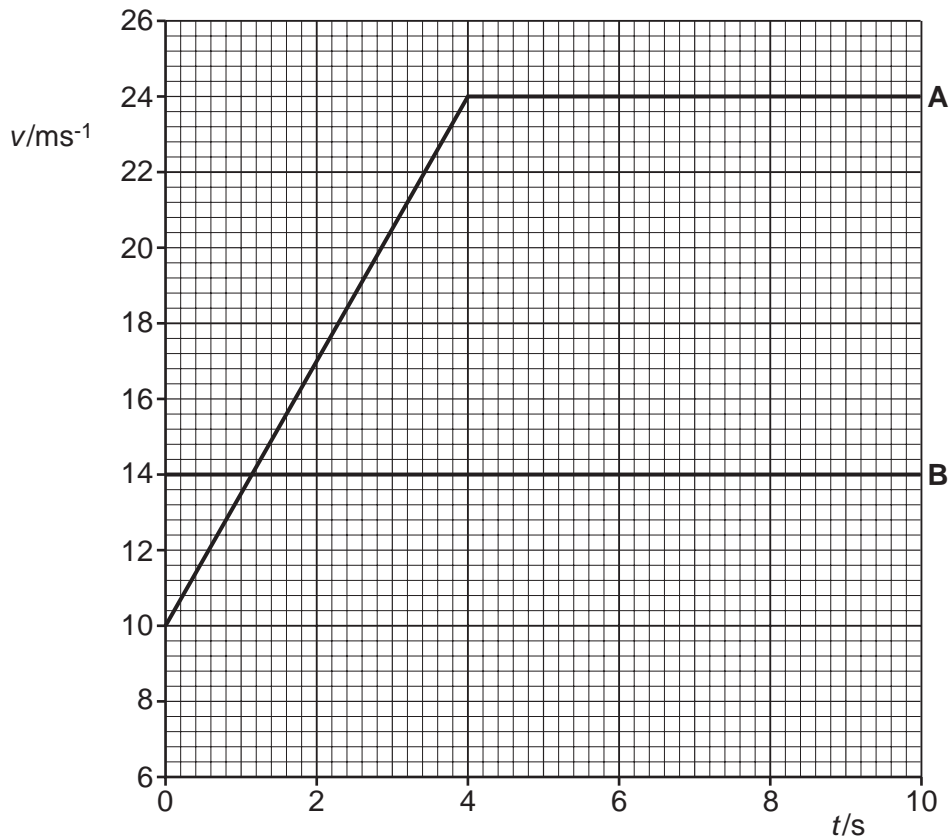

Fig. 1.1

At time $t = 0$, both cars are side-by-side.

(i) Describe the motion of car **A** from $t = 0$ to $t = 10$ s.

.....
.....
..... [2]

(ii) Calculate the distance travelled by car **A** in the first 4.0s.

distance = m [2]

(iii) Use Fig. 1.1 to find

1 the time at which both cars have the same velocity

time = s [1]

2 the time t at which car **A** overtakes car **B**.

$t =$ s [2]

[Total: 9]

4 Fig. 2.1 shows the path of water from a hose pipe.

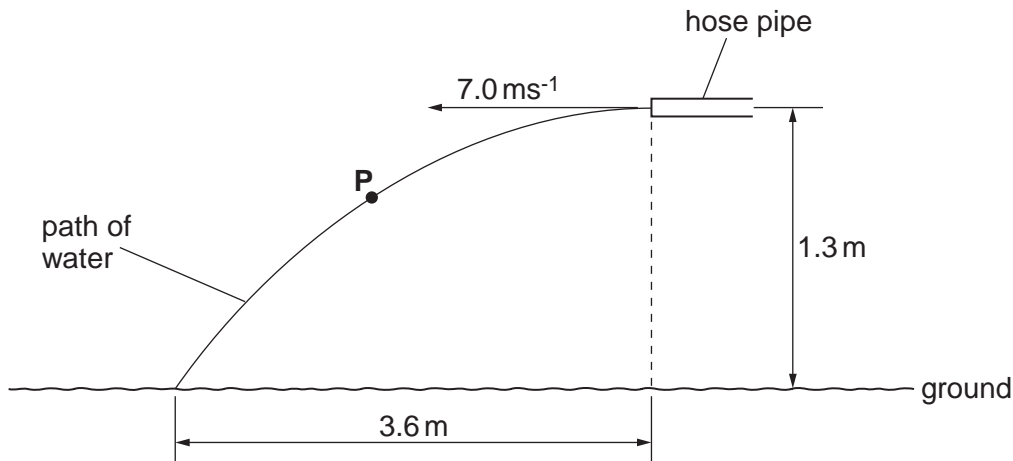

Fig. 2.1

The end of the horizontal hose pipe is at a height of 1.3 m from the ground. The initial horizontal velocity of the water is 7.0 m s^{-1} . The horizontal distance from the end of the hose pipe to the point where the water hits the ground is 3.6 m. You may assume that air resistance has negligible effect on the motion of the water jet.

- (a) On Fig. 2.1, draw an arrow to show the direction of the acceleration of the water at point P. (Mark this arrow A). [1]
- (b) Describe the energy conversion that takes place as the water travels from the end of the hose pipe to the ground.



In your answer, you should use appropriate technical terms, spelled correctly.

.....

.....

.....

..... [2]

- (c) Explain why the horizontal component of the velocity remains constant at 7.0 m s^{-1} .

.....

..... [1]

(d) Show that the water takes about 0.5s to travel from the end of the pipe to the ground.

[1]

(e) Show that the speed of the water when it hits the ground is 8.6 m s^{-1} .

[3]

[Total: 8]

5 (a) Define *velocity*.

.....
..... [1]

(b) Define *work done* by a force.

.....
..... [2]

(c) Fig. 3.1 shows a rider on a sledge sliding down an icy slope.

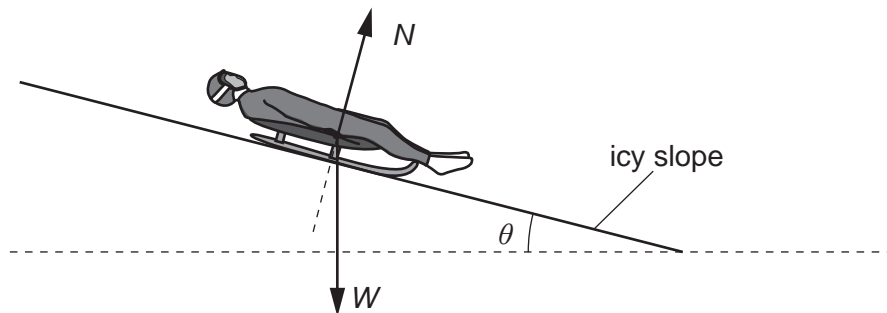

Fig. 3.1

The frictional forces acting on the sledge and the rider are negligible. The normal contact force N and the total weight W of the sledge and rider are shown.

(i) Explain why the force N does no work on the sledge as it slides down the slope.

.....
..... [1]

(ii) State and explain the force that causes the sledge and rider to accelerate down the slope.

.....
..... [1]

(d) Fig. 3.2 shows the velocity against time graph for the sledge and rider in (c) sliding down the icy slope.

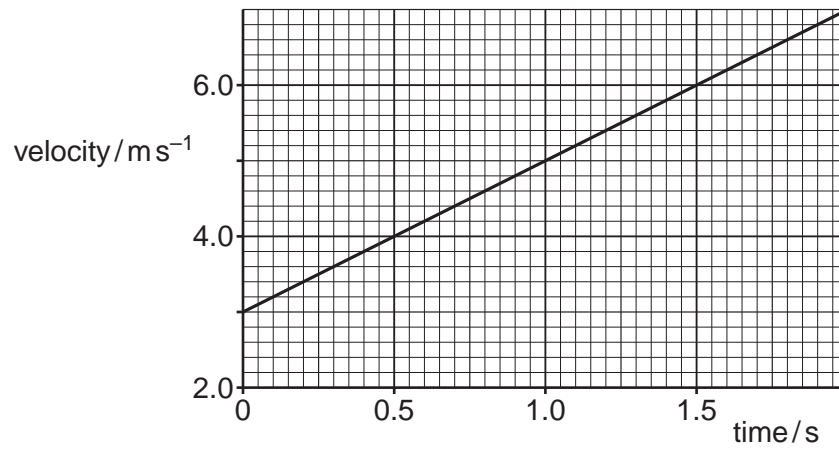

Fig. 3.2

(i) Use Fig. 3.2 to determine

1 the acceleration of the sledge and rider down the slope

acceleration = ms⁻² [2]

2 the angle made by the slope to the horizontal.

angle = ° [2]

(ii) The sledge crashes into a foam barrier at the bottom of the slope.

The velocity of the sledge just before the impact is 15 ms^{-1} . The sledge and rider take 3.5s to stop. The average decelerating force on the sledge and rider is 510N.

Calculate the total mass of the sledge and rider.

mass = kg [3]

[Total: 12]

- 6 Fig. 2.1 shows two masses **A** and **B** tied to the ends of a length of string. The string passes over a pulley. The mass **A** is held at rest on the floor.

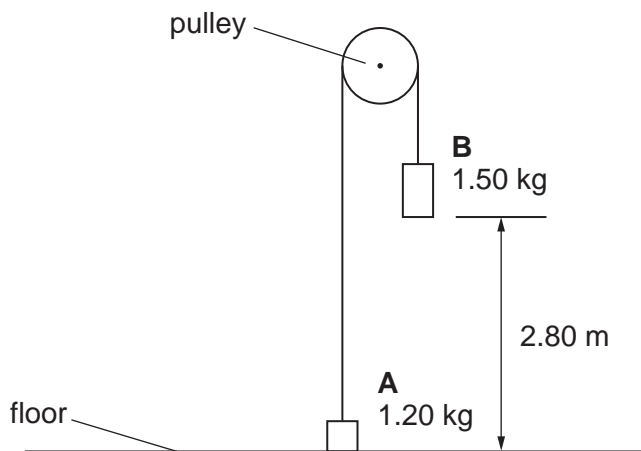

Fig. 2.1

The mass **A** is 1.20 kg and the mass **B** is 1.50 kg.

- (a) Calculate the weight of mass **B**.

weight = N [1]

- (b) Mass **B** is initially at rest at a height of 2.80 m above the floor. Mass **A** is then released. Mass **B** has a constant downward acceleration of 1.09 ms^{-2} . Assume that air resistance and the friction between the pulley and the string are negligible.

- (i) In terms of forces, explain why the acceleration of the mass **B** is less than the acceleration of free fall g .

.....
 [1]

- (ii) Calculate the time taken for the mass **B** to fall 1.40 m.

time = s [3]

(iii) Calculate the velocity of mass **B** after falling 1.40m.

velocity = ms^{-1} [2]

(iv) Mass **B** hits the floor at a speed of 2.47ms^{-1} . It **rebounds** with a speed of 1.50ms^{-1} . The time of contact with the floor is $3.0 \times 10^{-2} \text{s}$. Calculate the magnitude of the average acceleration of mass **B** during its impact with the floor.

acceleration = ms^{-2} [2]

[Total: 9]

7 (a) Explain why force is a vector quantity.



In your answer, you should use appropriate technical terms, spelled correctly.

.....
..... [1]

(b) Fig. 2.1 shows the forces acting on a water drop on the windscreen of a stationary car.

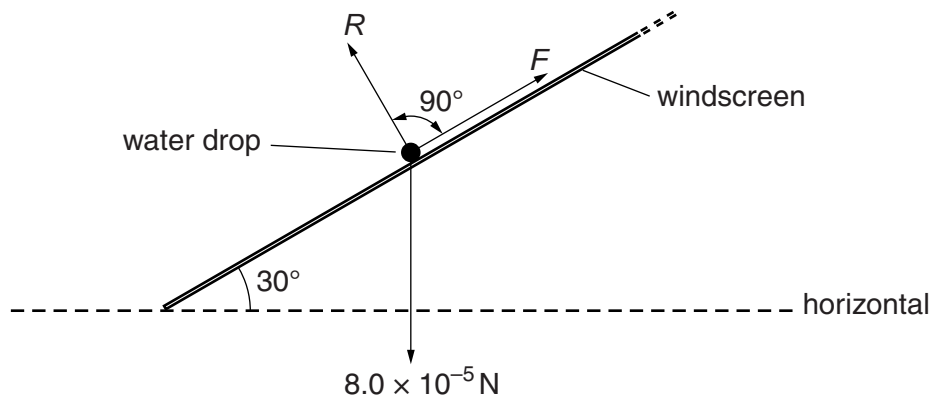

Fig. 2.1

The windscreen makes an angle of 30° to the horizontal. The weight of the water drop is $8.0 \times 10^{-5} \text{ N}$. The normal contact force on the water drop is R . There is also a force F acting on the water drop as shown. The water drop is **stationary**.

(i) Use Fig. 2.1 to determine the component of the weight of the water drop

1 perpendicular to the windscreen

component = N

2 parallel to the windscreen.

component = N
[2]

(ii) Determine the magnitude of F . Explain your answer.

.....

.....

.....

..... [2]

[Total: 5]

8 Fig. 4.1 shows a metal ball held stationary above a tube containing oil.

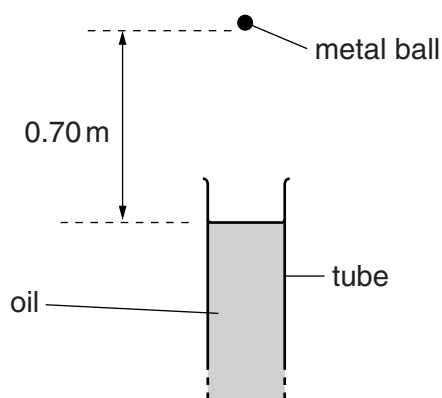

Fig. 4.1

- (a) The ball is 0.70 m above the surface of the oil in the tube. Calculate the time taken for the ball to reach the surface of the oil when it is dropped from this height. Assume air resistance has negligible effect on the motion of the ball.

time = s [3]

- (b) Fig. 4.2 shows the graph of velocity v against time t for the ball as it travels through the oil. The ball enters the oil at time $t = 0$.

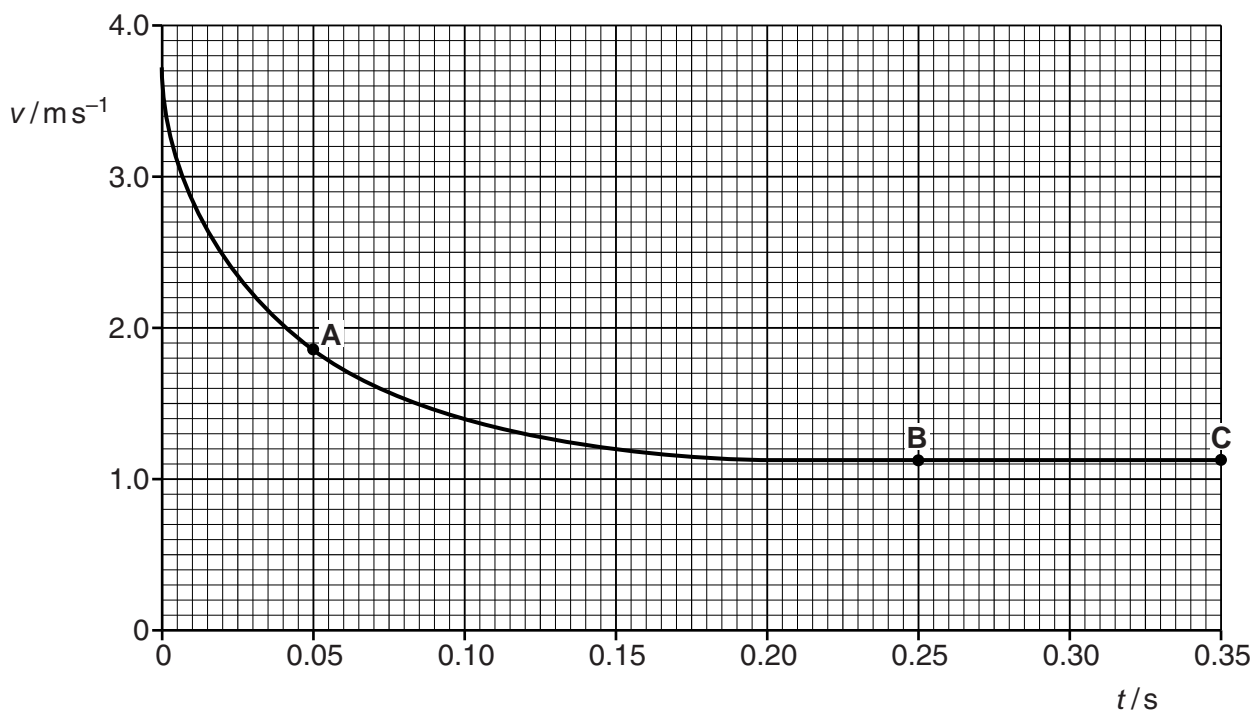

Fig. 4.2

- (i) Complete the sentence below.

The gradient of the graph is equal to the of the ball and
the area under the graph is equal to the [1]

- (ii) Use Fig. 4.2 to determine the magnitude of the deceleration of the ball at time $t = 0.05$ s (point **A**). Show your working.

deceleration = m s^{-2} [3]

- (iii) In terms of the **forces** acting on the ball, describe and explain its motion when

- 1 time $t = 0.05$ s (point **A**)

.....
.....
.....
.....
.....

- 2 time $t = 0.25$ s (point **B**).

.....
.....
.....
.....
.....

[4]

- (iv) Describe the energy transfers taking place between $t = 0.25$ s and $t = 0.35$ s (point **B** to **C**).

.....
.....
..... [1]

[Total: 12]